

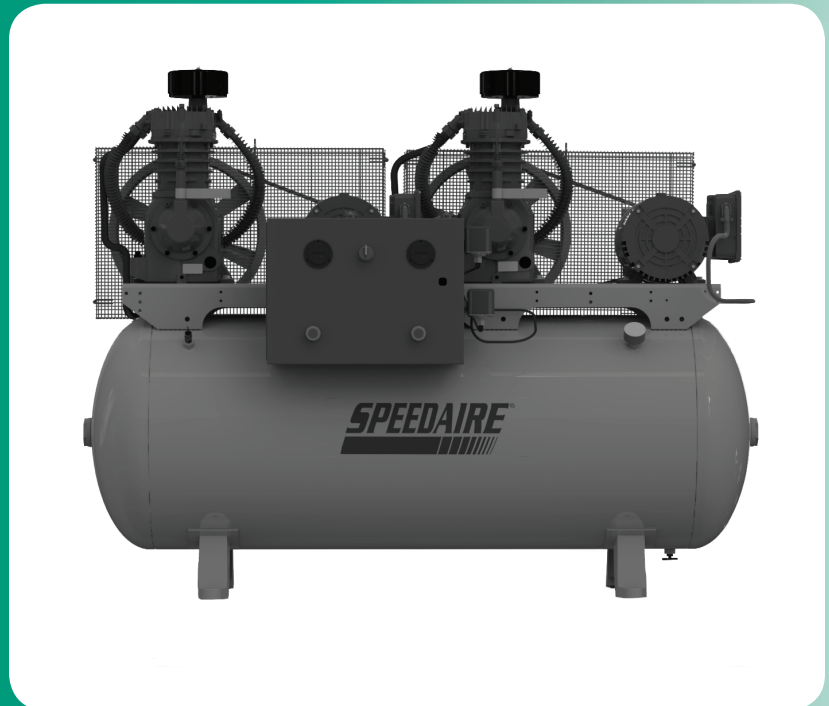

# SPEEDAIRE



## Two Stage Duplex Air Compressors

Models 35WC60, 35WC61, 35WC62, 35WC63



# **SPEEDAIRE**

**PLEASE READ AND SAVE  
THESE INSTRUCTIONS.  
READ CAREFULLY  
BEFORE ATTEMPTING  
TO ASSEMBLE, INSTALL,  
OPERATE OR MAINTAIN THE  
PRODUCT DESCRIBED.**

**PROTECT YOURSELF AND  
OTHERS BY OBSERVING ALL  
SAFETY INFORMATION. FAILURE  
TO COMPLY WITH INSTRUCTIONS  
COULD RESULT IN PERSONAL  
INJURY AND/OR PROPERTY DAMAGE!  
RETAIN INSTRUCTIONS FOR FUTURE  
REFERENCE.**

**PLEASE REFER TO BACK COVER  
FOR INFORMATION REGARDING  
SPEEDAIRE'S WARRANTY AND OTHER  
IMPORTANT INFORMATION.**

**Model #:** \_\_\_\_\_

**Serial #:** \_\_\_\_\_

**Purch. Date:** \_\_\_\_\_

*Form 5S7578 / Printed in USA  
02433 Version 2 04/2015  
© 2013 W.W. Grainger, Inc.  
All Rights Reserved*

## BEFORE YOU BEGIN

### **Introduction**

The Speedaire Two Stage Duplex Air Compressors are two stage, oil lubricated reciprocating compressors.

### **Duplex Models Include:**

- Compressor pump (x2)
- ASME air receiver with safety valve
- Electric motor (x2)
- Starter (x2)
- Pressure switch (x2)
- Hour meter
- Shut-off valve
- Deluxe Alternator Control Panel

<b>Quick Reference</b>
<b>Recommended Oil (2 Options)</b>
Single viscosity SAE 30 ISO100 nondetergent compressor oil. Part number 1WG50 or 4ZF21.
10W30 synthetic oil such as Mobil 1® or 1WG49.
<b>Oil Capacity</b>
Approximately 2 quarts (per pump)

## UNPACKING

**⚠ CAUTION** *Do not lift or move unit without appropriately rated equipment. Be sure the unit is securely attached to lifting device used. Do not lift unit by holding onto tubes or coolers. Do not use unit to lift other attached equipment.*

After unpacking the unit, inspect carefully for any damage that may have occurred during transit. Check for loose, missing or damaged parts. Check to be sure all supplied accessories are enclosed with the unit. In case of questions, damaged or missing parts, please call 1-855-504-5678 for customer assistance.

**⚠ WARNING** *Do not operate unit if damaged during shipping, handling or use. Damage may result in bursting and cause injury or property damage.*

### **Required Items - Not Included**

- Oil

**Getting To Know Your Compressor**

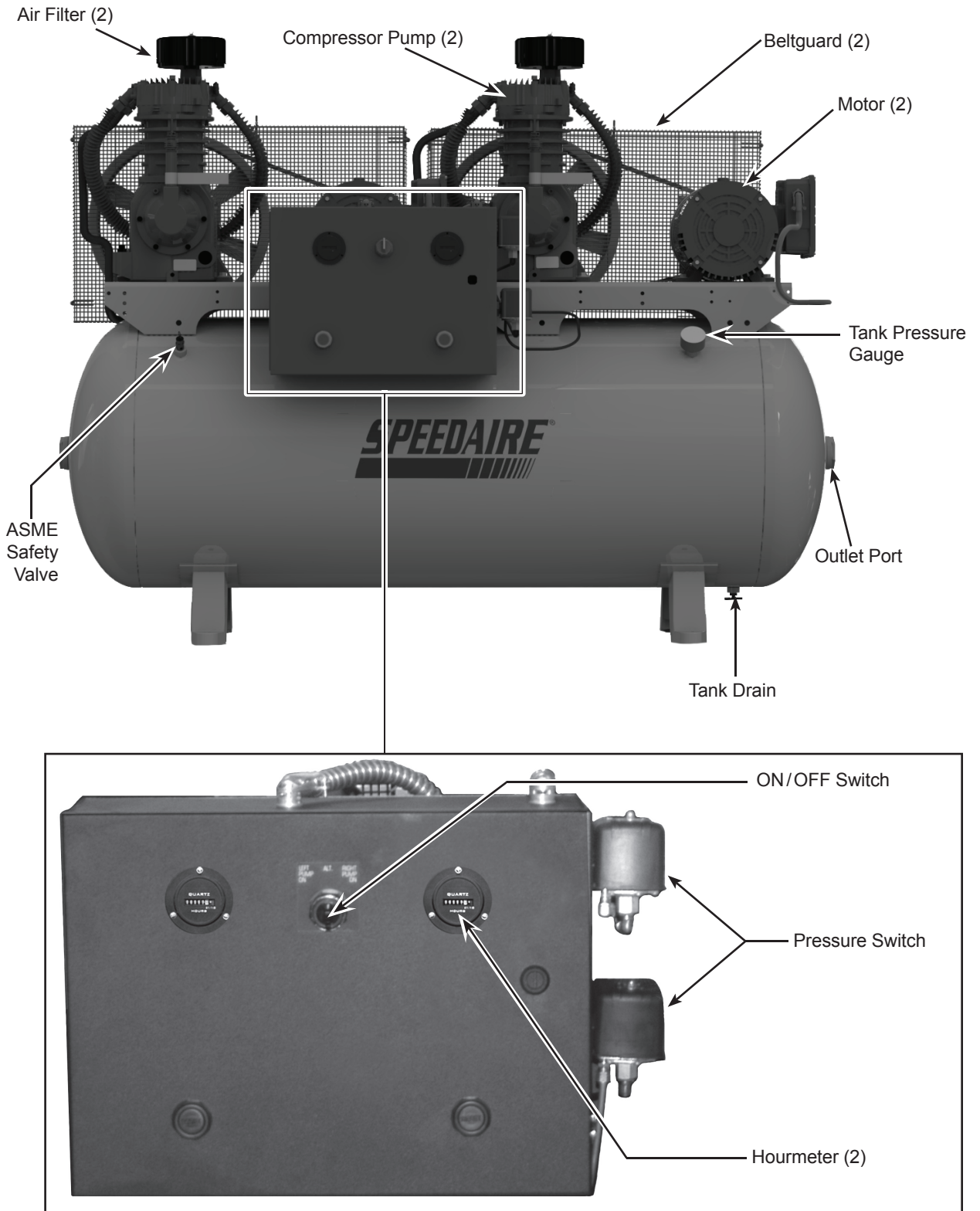

**Figure 1 - Duplex Air Compressor**

## GENERAL SAFETY INSTRUCTIONS

### Safety Guidelines

This manual contains information that is very important to know and understand. This information is provided for SAFETY and to PREVENT EQUIPMENT PROBLEMS. To help recognize this information, observe the following symbols.



**DANGER** *Danger indicates an imminently hazardous situation which, if not avoided, WILL result in death or serious injury.*



**WARNING** *Warning indicates a potentially hazardous situation which, if not avoided, COULD result in death or serious injury.*



**CAUTION** *Caution indicates a potentially hazardous situation which, if not avoided, MAY result in minor or moderate injury.*



**NOTICE** *Notice indicates important information, that if not followed, may cause damage to equipment.*

**IMPORTANT:** Information that requires special attention.

### Safety Symbols

The following Safety Symbols appear throughout this manual to alert you to important safety hazards and precautions.



*Wear Eye and Mask Protection*



*Read Manual First*



*Risk of Fire*



*Risk of Moving Parts*



*Risk of Hot Parts*



*Risk of Explosion*



*Risk of Fumes*



*Risk of Pressure*



*Risk of Shock*

### California Proposition 65



**WARNING** *This product or its power cord may contain chemicals known to the State of California to cause cancer and birth defects or other reproductive harm. Wash hands after handling.*



**WARNING** *You can create dust when you cut, sand, drill or grind materials such as wood, paint, metal, concrete, cement, or other masonry. This dust often contains chemicals known to cause cancer, birth defects, or other reproductive harm. Wear protective gear.*

### Important Safety Information

**Please read and save these instructions. Read carefully before attempting to assemble, install, operate or maintain the product described. Protect yourself and others by observing all safety information. Failure to comply with instructions could result in personal injury and/or property damage! Retain instructions for future reference.**

This manual contains important safety, operational and maintenance information. If you have any questions, please call 1-855-504-5678 for customer assistance.

Since the air compressor and other components (material pump, spray guns, filters, lubricators, hoses, etc.) used make up a high pressure pumping system, the following safety precautions must be observed at all times:

## Important Safety Information (Continued)

### **⚠ DANGER**

#### **BREATHABLE AIR WARNING**

This compressor/pump is not equipped and should not be used “as is” to supply breathing quality air. For any application of air for human consumption, the air compressor/pump will need to be fitted with suitable in-line safety and alarm equipment. This additional equipment is necessary to properly filter and purify the air to meet minimal specifications for Grade D breathing as described in Compressed Gas Association Commodity Specification G 7.1, OSHA 29 CFR 1910. 134, and/or Canadian Standards Associations (CSA).

#### **DISCLAIMER OF WARRANTIES**

In the event the compressor is used for the purpose of breathing air application and proper in-line safety and alarm equipment is not simultaneously used, existing warranties shall be voided, and Campbell Hausfeld disclaims any liability whatsoever for any loss, personal injury or damage.

### **General Safety**



- Read all manuals included with this product carefully. Be thoroughly familiar with the controls and the proper use of the equipment.
- Follow all local electrical and safety codes as well as the United States National Electrical Codes (NEC) and Occupational Safety and Health Act (OSHA).
- Only persons well acquainted with these rules of safe operation should be allowed to use the compressor.
- Keep visitors away and NEVER allow children in the work area.
- Wear safety glasses and use hearing protection when operating the unit.
- Do not stand on or use the unit as a handhold.
- Before each use, inspect compressed air system and electrical components for signs of damage, deterioration, weakness or leakage. Repair or replace defective items before using.
- Check all fasteners at frequent intervals for proper tightness.



**⚠ WARNING** *Motors, electrical equipment and controls can cause electrical arcs that will ignite a flammable gas or vapor. Never operate or repair in or near a flammable gas or vapor. Never store flammable liquids or gases in the vicinity of the compressor.*



**⚠ WARNING** *Never operate compressor without a beltguard. This unit can start automatically without warning. Personal injury or property damage could occur from contact with moving parts.*

- Do not wear loose clothing or jewelry that will get caught in the moving parts of the unit.



**⚠ CAUTION** *Compressor parts may be hot even if the unit is stopped.*

- Keep fingers away from a running compressor; fast moving and hot parts will cause injury and/or burns.
- If the equipment should start to vibrate abnormally, STOP the engine/motor and check immediately for the cause. Vibration is generally an indication of trouble.
- To reduce fire hazard, keep engine/motor exterior free of oil, solvent, or excessive grease.

**⚠ WARNING** *An ASME code safety relief valve with a setting no higher than the Maximum Allowable Working Pressure (MAWP) of the tank MUST be installed in the air lines or in the tank for this compressor. The ASME safety valve must have sufficient flow and pressure ratings to protect the pressurized components from bursting. The flow rating can be found in the parts manual. The safety valve in the intercooler does not provide system protection.*

**⚠ WARNING** *Maximum operating pressure is 175 psi for two-stage compressors. Do not operate with pressure switch or pilot valves set higher than 175 psi (two-stage).*

- Never attempt to adjust ASME safety valve. Keep safety valve free from paint and other accumulations.

**⚠ WARNING**

**Never attempt to repair or modify a tank! Welding, drilling or any other modification will weaken the tank resulting in damage from rupture or explosion. Always replace worn, cracked or damaged tanks.**

**NOTICE**

**Drain liquid from tank daily.**

- Tanks rust from moisture build-up, which weakens the tank. Make sure to drain tank regularly and inspect periodically for unsafe conditions such as rust formation and corrosion.
- Fast moving air will stir up dust and debris which may be harmful. Release air slowly when draining moisture or depressurizing the compressor system.

**Spraying Precautions****⚠ WARNING**

**Do not spray flammable materials in vicinity of open flame or near ignition sources including the compressor unit.**



- Do not smoke when spraying paint, insecticides, or other flammable substances.
- Use a face mask/respirator when spraying and spray in a well ventilated area to prevent health and fire hazards.
- Do not direct paint or other sprayed material at the compressor. Locate compressor as far away from the spraying area as possible to minimize overspray accumulation on the compressor.
- When spraying or cleaning with solvents or toxic chemicals, follow the instructions provided by the chemical manufacturer.

**Save These Instructions**  
**Do Not Discard**

The **DANGER, WARNING, CAUTION, and NOTICE** notifications and instructions in this manual cannot cover all possible conditions and situations that may occur. It must be understood by the operator that caution is a factor which cannot be built into this product, but must be supplied by the operator.

**SPECIFICATIONS**

	<b>35WC60</b>	<b>35WC61</b>	<b>35WC62</b>	<b>35WC63</b>
Motor HP	10 (5 x 2)	10 (5 x 2)	15 (7.5 x 2)	15 (7.5 x 2)
Power	230V	208-230/460V	230V	208-230/460V
Phase	1	3	1	3
Displacement CFM	42.2 (21.1 x 2)	42.2 (21.1 x 2)	62.8 (31.4 x 2)	62.8 (31.4 x 2)
Air Delivery CFM at Max Pressure	33.2 (16.6 x 2)	33.2 (16.6 x 2)	50.2 (25.1 x 2)	50.2 (25.1 x 2)
Amps	44 amps	28.4-25.4/12.8 amps	62 amps	39.6-35.8/18 amps
Max PSI	175	175	175	175
Pump RPM	685	685	1020	1020
Tank Capacity	120 gallons	120 gallons	120 gallons	120 gallons
Unit Weight	900 lbs	900 lbs	900 lbs	900 lbs

**DIMENSIONS**

	<b>35WC60</b>	<b>35WC61</b>	<b>35WC62</b>	<b>35WC63</b>
Length	69 inches	69 inches	69 inches	69 inches
Width	32 inches	32 inches	32 inches	32 inches
Height	51 inches	51 inches	51 inches	51 inches





- ⚠ WARNING** *Disconnect, tag and lock out power source then release all pressure from the system before attempting to install, service, relocate or perform any maintenance.*
- ⚠ CAUTION** *Do not lift or move unit without appropriately rated equipment. Be sure the unit is securely attached to lifting device used. Do not lift unit by holding onto tubes or coolers. Do not use unit to lift other attached equipment.*
- ⚠ CAUTION** *Never use the wood shipping skids for mounting the compressor.*

**Picking the Location**

Install and operate unit at least 18 inches from any obstructions in a clean, well ventilated area. The surrounding air temperature should not exceed 100° F. This will ensure an unobstructed flow of air to cool compressor and allow adequate space for maintenance.

- ⚠ CAUTION** *Do not locate the compressor air inlet near steam, paint spray, sandblast areas or any other source of contamination.*

**NOTE:** If compressor operates in a hot, moist environment, supply compressor pump with clean, dry outside air. Supply air should be piped in from external sources.

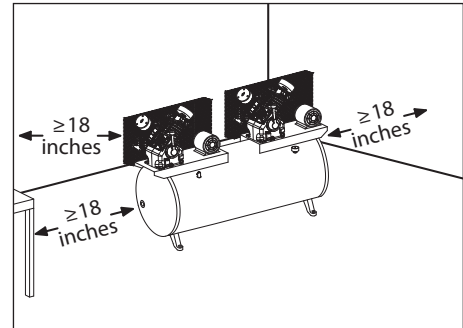

**Figure 2 - Location**

**Tank Mounting**

The tank should be bolted into a flat, even, concrete floor or on a separate concrete foundation. Vibration isolators should be used between the tank leg and the floor. Model 2LVP7 isolator pads are recommended for horizontal units. Isolator pads are included with fully packaged models.

When using isolator pads, **do not draw bolts tight**. Allow the pads to absorb vibrations. When isolators are used, a flexible hose or coupling should be installed between the tank and service piping.

- ⚠ WARNING** *Failure to properly install the tank can lead to cracks at the welded joints and possible bursting.*

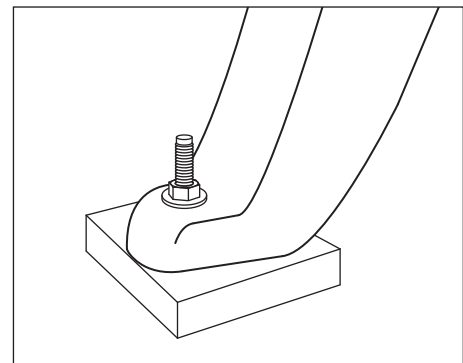

**Figure 3 - Isolator pad**

**Piping**

- ⚠ WARNING** *Never use plastic (PVC) pipe for compressed air. Serious injury or death could result.*

Any tube, pipe or hose connected to the unit must be able to withstand the temperature generated and retain the pressure. All pressurized components of the air system must have a pressure rating of 200 psi or higher. Incorrect selection and installation of any tube, pipe or hose could result in bursting and injury. Connect piping system to tank using the same size fitting as the discharge port.

**Minimum Pipe Size For Compressed Air Line**

CFM	Length Of Piping System			
	25 feet	50 feet	100 feet	250 feet
10	1/2 inch	1/2 inch	3/4 inch	3/4 inch
20	3/4 inch	3/4 inch	3/4 inch	1 inch
40	3/4 inch	1 inch	1 inch	1 inch
60	3/4 inch	1 inch	1 inch	1 inch
100	1 inch	1 inch	1 inch	1-1/4 inch



## INSTALLATION INSTRUCTIONS (CONTINUED)

### Installing A Shut-Off Valve

A shut-off valve should be installed on the discharge port of the tank to control the air flow out of the tank. The valve should be located between the tank and the piping system.

**▲ WARNING** *Never install a shut-off valve between the compressor pump and the tank. Personal injury and/or equipment damage may occur. Never use reducers in discharge piping.*

When creating a permanently installed system to distribute compressed air, find the total length of the system and select pipe size from the chart. Bury underground lines below the frost line and avoid pockets where condensation can gather and freeze.

Apply air pressure to the piping installation and make sure all joints are free from leaks BEFORE underground lines are covered. Before putting the compressor into service, find and repair all leaks in the piping, fittings and connections.

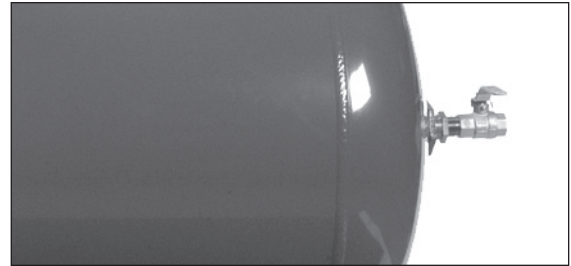

Figure 4 - Shut-off Valve

### Wiring

**▲ WARNING** *All wiring and electrical connections must be performed by a qualified electrician familiar with induction motor controls. Installations must be in accordance with local and national codes.*

**▲ WARNING** *Overheating, short circuiting and fire damage will result from inadequate wiring.*

Wiring must be installed in accordance with National Electrical Code and local codes and standards that have been set up covering electrical apparatus and wiring. These should be consulted and local ordinances observed. Be certain that adequate wire sizes are used, and that:

1. Service is of adequate ampere rating.
2. The supply line has the same electrical characteristics (voltage, cycles and phase) as the motor. Refer to motor name plate for electrical ratings and specifications.
3. The line wire is the proper size and that no other equipment is operated from the same line. The chart gives minimum recommended wire sizes for compressor installations.

#### Minimum Wire Size (Use 75°C Copper Wire)

Make sure voltage is correct with the motor wiring.

**NOTE:** If using 208 volts single phase, make sure the motor name plate states it is rated for 208 volts single phase. 230 volt single phase motors do not work on 208 volts unless they have the 208 volt rating.

HP	Amps	Single Phase		Three Phase
		230V	208/230V	460V
10.0 (5 x 2)	See page 6	8 AWG	8 AWG	10 AWG
15.0 (7.5 x 2)	See page 6	6 AWG	8 AWG	10 AWG

**Recommended wire sizes may be larger than the minimum set up by local ordinances. If so, the larger size wire should be used to prevent excessive line voltage drop. The additional wire cost is very small compared with the cost of repairing or replacing a motor electrically "starved" by the use of supply wires which are too small.**

## INSTALLATION INSTRUCTIONS (CONTINUED)

### Grounding



#### **⚠ WARNING**

**Improperly grounded electrical components are shock hazards. Make sure all the components are properly grounded to prevent death or serious injury.**

This product **must** be grounded. Grounding reduces the risk of electrical shock by providing an escape wire for the electric current if short circuit occurs. This product must be installed and operated with a power cord or cable that has a grounding wire.

### Breakers and Fuses

The entire electrical system should be checked by a certified electrician. Time delay breakers and fuses are required for this compressor. A tripped breaker or blown fuses may indicate a direct short to ground, high current draw, improper wiring, incorrect fuse or breaker size and/or type. This needs to be evaluated by a certified electrician.

### Motor Hookup and Starter Installation

Branch circuit protection must be provided as specified in the United States National Electrical Code, Chapter 2, "Wiring Design and Protection." Article 210, using the applicable article "For Motors and Motor Controllers," (Article 430, Table 430-1 52).

**IMPORTANT:** Overload protection is required for all motors.

Motors used do not have built-in overload protection. A magnetic starter is required. All include a magnetic starter. Refer to the wiring diagrams for electrical installation.

### Direction of Rotation

**NOTE:** Improper rotation will result in reduced compressor life.

The direction of rotation must be counterclockwise (as shown by the arrow on the flywheel in Figure 5) while facing the flywheel side of the pump. The motor nameplate will show wiring information for counterclockwise rotation.

The proper direction is very important. The direction of rotation of 3 phase motors can be reversed by interchanging any two motor-line leads. For single phase motors, refer to the motor nameplate.

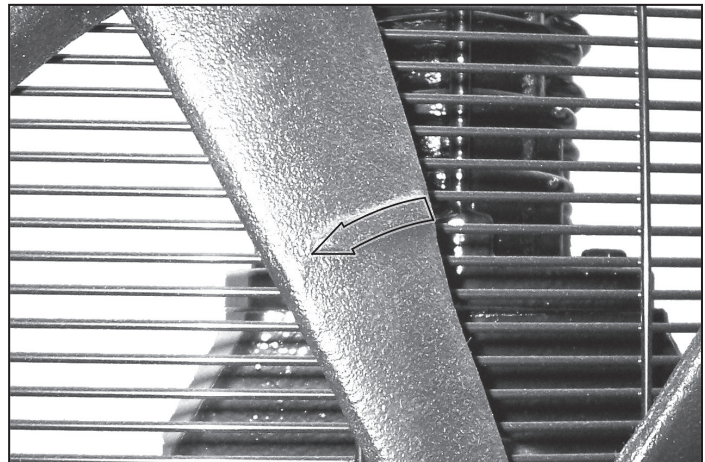

**Figure 5 - Direction of rotation**



**INSTALLATION INSTRUCTIONS  
(CONTINUED)**

**Lubrication**

**⚠ CAUTION** *This unit contains no oil. Before operating compressor, fill to the center of the sight gauge (see Figure 7).*

**⚠ CAUTION** *Using any other type of oil may shorten pump life and damage valves.*

<b>Recommended Oil (2 Options)</b>
Single viscosity SAE 30 ISO100 nondetergent compressor oil. Part number 1WG50 or 4ZF21.
10W30 synthetic oil such as Mobil 1® or 1WG49.
<b>Oil Capacity</b>
Approximately 2 quarts (per pump)

Fill the pump with oil to the center of the sight gauge using oil fill opening (see Figure 7). **Do NOT fill the pump through the breather cap opening as this may cause oil to leak and spray out during operation.**

**NOTE:** Some residual oil may still be in the pump from factory testing leaving a thin coat on the sight gauge; however, there is not enough oil to operate the unit.

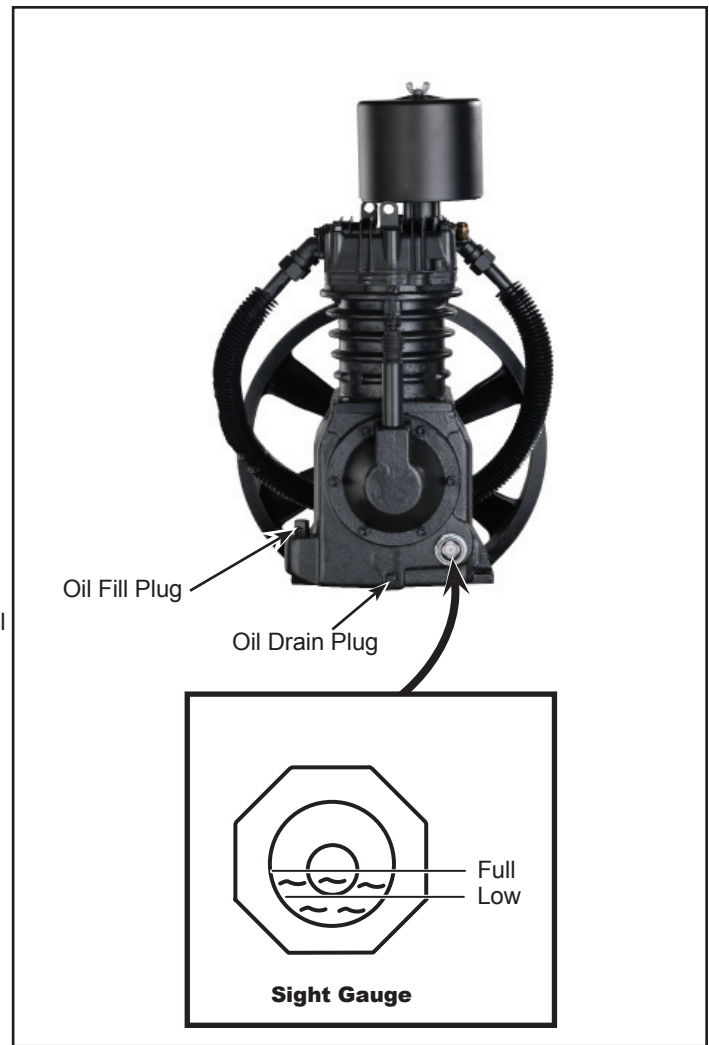

**Figure 7- Lubrication**

## OPERATING INSTRUCTIONS

**IMPORTANT:** Check motor rotation before operating the compressor.

All lubricated compressor pumps discharge some condensed water and oil with the compressed air. Install appropriate water/oil removal equipment and controls as necessary for the intended application.

### NOTICE

**Failure to install appropriate water/oil removal equipment may result in damage to machinery or workpiece.**



### Guarding

#### ⚠ WARNING

**The belt guard provided must be installed before operating the unit.**

All moving parts must be guarded. All electrical covers must be installed before turning on the power.

### Recommended Break-In Period

The compressor should be run continuously for one hour to allow proper seating of the piston rings.

1. Open drain cock completely and run the compressor for 60 minutes.
2. Turn off the compressor and close drain cock. The compressor is now ready for use.

### Duplex Alternating System

This compressor has an alternating system with a single power input. This system evenly distributes the workload between the two motor/pump units. If system pressure falls below 125 psi, both motor/pump units run. As tank pressure exceeds 155 psi, one motor/pump unit shuts off. This is the motor/pump unit which will run first the next time the tank needs pressure up to 175 psi. If the air pressure in the tank drops below 145 psi, but remains above 125 psi, only one motor/pump unit will run. Motor/pump units will take turns pressurizing the tank so that the motor/pump unit which has been idle longest pressurizes the tank.

### Pressure Switch, Start - Stop

**NOTE:** This compressor has a maximum operating pressure of 175 psi. Do not alter pressure settings on control components above this limit.

The pressure switch contains an unloader which is a small valve that vents air to allow the motor to start easily.

The unloader valve on the pressure switch should hiss for a short period of time when the compressor shuts off. This relieves the head and the exhaust tubing of any pressure and allows the compressor to start under no load. Because compressors have high starting torque the unloader is necessary for proper starting of the compressor.

The check valve is a one way valve that keeps the air in the tank when the unit shuts off. The easiest way to determine if the check valve is working properly is to make sure that the pressure switch unloader quits hissing after the compressor shuts off. The hissing should last for several seconds and then quit.

### Crankcase Breather

During severe operating conditions or initial start-up, some oil may accumulate at the crankcase breather opening. This is normal and will diminish as the pump accumulates run time and the piston rings become fully seated.

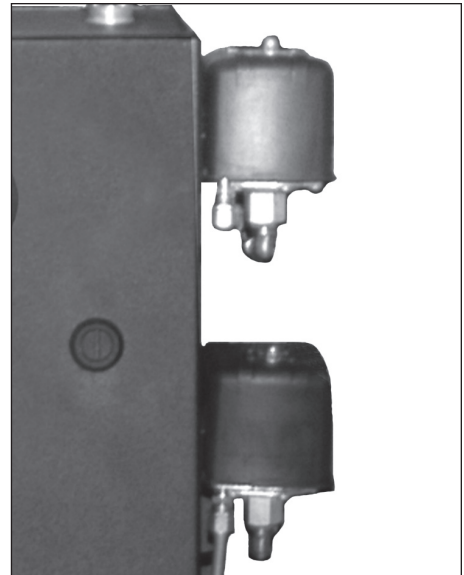

**Figure 8 - Pressure Switches**



### **Draining Tank**

Condensate must be drained from the tank daily. These duplex models include a manual tank drain.

### **Shuttle valve**

**IMPORTANT:** Do not replace the shuttle valve with a pipe tee or pipe cross.

The plumbing on the compressor includes a shuttle valve between the pressure switch unloader valve and the two in-tank check valves. This shuttle valve prevents pressure from the discharge tube of one compressor from flowing back into the compressor which is not running. A back flow of pressurized air into the off compressor discharge line can damage the pump and motor.

### **Duty Cycle**

Each pump on this compressor is designed to operate up to 75% of the time. Long-term or on-time operation over 75% could decrease the life of the pump and motor.

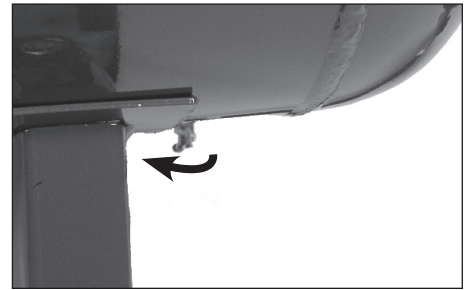

**Figure 9 - Manual Tank Drain**

## TROUBLESHOOTING GUIDE FOR NEW INSTALLATIONS

Symptom	Possible Cause(s)	Corrective Action
Unit fails to start - Motor makes no noise	1. Insufficient power to compressor	1. Source electric to the compressor is either the incorrect voltage, insufficient wire size to carry the load, the fuse box or breaker box is not sufficient to carry the load requirements to the compressor.
	2. Unit wired incorrectly	2. Any wiring other than what is stated in the manual could cause a malfunction (see Wiring Section)
	3. Wrong voltage supplied to unit	3. Make sure voltage is correct with the motor wiring (see Wiring Section)
	4. Loose electrical connections	4. The entire electrical system should be checked by a certified electrician. The incoming wires and the compressor electrical connections should be checked. Loose connections will cause malfunctions
	5. Wrong size wiring	5. Check that wire size is rated for the current of the compressor. State and local codes vary widely and need to be checked before installation
	6. Blown fuse and/or tripped breaker	6. The breaker and fuses required for this unit must be time delay. A tripped breaker or blown fuse may result from a direct short to ground, high current draw, improper wiring, incorrect fuse or breaker size and/or type. This needs to be evaluated by a service center or certified electrician
	7. Starter overload tripped	7. Check and reset if necessary. If the overload trips after the initial reset, refer to the below section "reset trips on starter"
Unit fails to start - Motor hums	1. Unit wired incorrectly	1. Any wiring other than what is stated in the manual could cause a malfunction (see Wiring Section)
	2. Wrong voltage	2. Make sure voltage is correct with the motor wiring (see Wiring Section)
	3. Loose electrical connections	3. The entire electrical system should be checked by a certified electrician. The incoming wires and the compressor electrical connections should be checked. Loose connections will cause malfunctions
Reset trips on starter	1. Unit wired incorrectly	1. Check voltage, wire size, etc. This problem needs to be evaluated and corrected (see Wiring Section)
	2. Wrong voltage	2. Make sure voltage is correct with the motor wiring (see Wiring Section)
	3. Wrong size wiring	3. Check to make sure wire size is rated for the current of the compressor. Check that wire size is rated for the current of the compressor. State and local codes vary widely and need to be checked before installation
Unit starts but does not get to full speed	1. Insufficient power to compressor	1. Source electric to the compressor is either the incorrect voltage, insufficient wire size to carry the load, the fuse box or breaker box is not sufficient to carry the load requirements to the compressor
	2. Loose electrical connections	2. The entire electrical system should be checked by a certified electrician. The incoming wires and the compressor electrical connections should be checked. Loose connections will cause malfunctions
Unit does not make any or very little air	1. Drain valve open	1. Make sure the drain valve at the bottom of the tank is closed
	2. Air leak	2. Check the entire system for leaks, including the compressor unit and any piping attached to the compressor
	3. Restricted or blocked intake	3. Make sure that the air intake of the compressor is not blocked in any way

*Continued on next page*



## TROUBLESHOOTING GUIDE FOR NEW INSTALLATIONS (CONTINUED)

Symptom	Possible Cause(s)	Corrective Action
Unit runs very noisy	<ol style="list-style-type: none"> <li>1. Damage to the compressor</li> <li>2. Loose fasteners</li> <li>3. Loose flywheel or pulley</li> <li>4. Improper installation</li> </ol>	<ol style="list-style-type: none"> <li>1. Check to make sure the compressor has not been damaged in the shipping or installation. Make sure the belt guard was not damaged. Belt guard should not be making contact with flywheel or pulley</li> <li>2. Check all bolts and nuts to assure they did not loosen during shipping</li> <li>3. Check to assure pulley and flywheel are correctly tightened</li> <li>4. If unit is left on skid it may cause excessive vibration. Remove unit from skid and mount loosely to floor with vibration pads and anchor bolts. Do not tighten bolts tight. Leave nut loose approximately 1/8 inch from compressor foot</li> </ol>
Oil in discharge air or out crankcase breather	<ol style="list-style-type: none"> <li>1. Break in period</li> <li>2. Wrong type of oil</li> <li>3. Improper environment</li> </ol>	<ol style="list-style-type: none"> <li>1. Some oil in the exhaust air is normal during the break-in period and during heavy usage after the break-in period. Oil discharge should reduce as hours are accumulated on the unit</li> <li>2. Do not use SAE-30 automotive type oil. Using the wrong oil can cause problems with the pump and will void the warranty. Only use the oils that the operating manual recommends (see Lubrication section)</li> <li>3. Unit should not be installed in a poorly vented area or exposed to extreme cold or hot conditions. Normal operating range should be between 32°F and 100°F</li> </ol>
Compressor seems to run hot	Rotation incorrect	Check to make sure the compressor is running the direction of the flywheel arrow. Air flow should be so that the flywheel directs air across the head of the pump. Standing in front of the compressor (non-belt guard side) air should flow back to front

## TROUBLESHOOTING GUIDE FOR UNITS IN SERVICE FOR A PERIOD OF TIME

Symptom	Possible Cause(s)	Corrective Action
Motor does not run	<ol style="list-style-type: none"> <li>Loose electrical connections</li> <li>Blown fuse and/or tripped breaker</li> <li>Starter overload tripped</li> <li>Defective capacitor</li> <li>Defective magnetic starter</li> </ol>	<ol style="list-style-type: none"> <li>The entire electrical system should be checked by a certified electrician. The incoming wires and the compressor electrical connections should be checked. Loose connections will cause malfunctions</li> <li>The breaker and fuses required for this unit must be time delay. A tripped breaker or blown fuse may result from a direct short to ground, high current draw, improper wiring, incorrect fuse or breaker size and/or type. This needs to be evaluated by a service center or certified electrician</li> <li>Check and reset if necessary. If the overload trips after the initial reset, refer to the section of the manual that covers this issue</li> <li>Check and replace (if necessary) defective capacitor</li> <li>First check for any loose wiring and tighten if loose. Check and replace (if necessary) defective magnetic starter</li> </ol>
Motor hums; motor draws high amps, trips overload, trips breaker, or blows fuse on start up	<ol style="list-style-type: none"> <li>Defective pressure switch unloader</li> <li>Defective check valve - constant loss of tank pressure</li> <li>Loose electrical connections</li> <li>Defective capacitor</li> <li>Valve problem or blown gasket</li> </ol>	<ol style="list-style-type: none"> <li>Drain the tank of all pressure. Restart compressor under no load. If compressor is able to start, then the unloader needs to be checked. If this problem is not corrected it will fail the motor and / or other electrical components</li> <li>Determine if the check valve is working properly - pressure switch unloader should quit hissing after the compressor shuts off. If the hissing continues and if there is a constant loss of tank pressure, then the check valve is not working properly. Replace check valve</li> <li>The entire electrical system should be checked by a certified electrician. The incoming wires and the compressor electrical connections should be checked. Loose connections will cause malfunctions</li> <li>Check and replace (if necessary) defective capacitor</li> <li>Check gasket and replace as needed. Other symptoms occur when a valve is not sealing or a gasket is blown such as higher than normal amp draw which may trip out the overload or breaker</li> </ol>
Compressor runs but builds pressure slowly	<ol style="list-style-type: none"> <li>Air leak</li> <li>Dirty air filter</li> <li>Valve problem or blown gasket</li> <li>Tank cracked</li> </ol>	<ol style="list-style-type: none"> <li>Check the entire system for leaks, including the compressor unit and any piping attached to the compressor</li> <li>Air filters need to be changed regularly based on usage and environment. A dirty filter may appear to be clean. Change filters often</li> <li>Check gasket and replace as needed. Other symptoms occur when a valve is not sealing or a gasket is blown such as higher than normal amp draw which may trip out the overload or breaker</li> <li>Replace the tank. <b>The unit should not be run under any conditions.</b> Tanks cannot be welded or patched</li> </ol>
Interstage safety valve pops off when the unit is running	<ol style="list-style-type: none"> <li>Malfunctioning interstage safety valve</li> <li>Low head bolt torque</li> <li>Defective interstage safety valve</li> </ol>	<ol style="list-style-type: none"> <li>Valve problem or blown gasket. High pressure air backflows into the low pressure side of the pump. This is caused by valve leakage or blown gasket</li> <li>Check and retighten head bolts to specified torque</li> <li>Replace interstage safety valve. Under no circumstances plug the safety valve port</li> </ol>
Oil out breather	<ol style="list-style-type: none"> <li>Worn rings or scored cylinder</li> <li>Compressor running hot</li> </ol>	<ol style="list-style-type: none"> <li>Replace rings and/or replace cylinder</li> <li>Make sure compressor is running the correct rotation. Compressor should be clean and in a well ventilated area. Oil should be changed on regular intervals according to the specifications listed in the manual. Air filter must be changed as it gets dirty</li> </ol>

Continued on next page

## TROUBLESHOOTING GUIDE FOR UNITS IN SERVICE FOR A PERIOD OF TIME (CONTINUED)

Symptom	Possible Cause(s)	Corrective Action
Milky oil in crankcase	<ol style="list-style-type: none"> <li>1. Low usage of compressor - water is condensing in the crankcase</li> <li>2. Wrong type of oil</li> <li>3. Improper environment</li> <li>4. Rotation incorrect</li> <li>5. Slight leakage of tank check valve</li> </ol>	<ol style="list-style-type: none"> <li>1. Run the compressor continuously for 1 hour. The heat generated during this running period will evaporate the moisture out of the oil</li> <li>2. Do not use SAE-30 automotive type oil. Using the wrong oil can cause various problems with the pump and will void the warranty. Only use the oils that the operating manual recommends</li> <li>3. Unit should not be installed in a poorly vented area or exposed to extreme cold or hot conditions. Normal operating range should be between 32°F and 100°F</li> <li>4. Check to make sure the compressor is running the direction of the flywheel arrow. Air flow should be so that the flywheel directs air across the head of the pump. Standing in front of the compressor (non-belt guard side) air should flow back to front</li> <li>5. Air cools and condensates, then leaks back into the pump. Draining tank of air after use will normally take care of this situation</li> </ol>
Pressure switch continually blows air out the unloader valve	Defective check valve	Replace check valve
Pressure switch does not release air when the compressor shuts off.	Pressure switch unloader not working properly	Drain the tank of all pressure. Restart compressor under no load. If compressor is able to start, then the unloader needs to be checked. If this problem is not corrected it will fail the motor and / or other electrical components
Compressor will not shut off	<ol style="list-style-type: none"> <li>1. Defective pressure switch</li> <li>2. Defective safety valve</li> </ol>	<ol style="list-style-type: none"> <li>1. Setting too high. Replace pressure switch</li> <li>2. Make sure tank pressure gauge is reading correctly and if necessary replace tank safety valve</li> </ol>
Unit vibrates excessively	<ol style="list-style-type: none"> <li>1. Loose fasteners</li> <li>2. Loose pulley, loose belt or misalignment or pulleys</li> <li>3. Defective pump</li> </ol>	<ol style="list-style-type: none"> <li>1. This includes mounting bolts for the pump, motor, belt guard, mag. starter, etc. Check for loose fasteners as part of a routine maintenance schedule. Tighten any loose fasteners</li> <li>2. The pulley and belt may need to be tightened over time. The pulleys may need to be realigned to assure proper belt wear and lower vibration. These should be checked as part of regular maintenance</li> <li>3. A defective pump includes knocking or making noises not normal to the pump design. Severe oil out the breather usually indicates ring or cylinder wear. Low pump performance could indicate valve problems. There are numerous symptoms associated with a defective pump. The pump will need to be evaluated</li> </ol>
Water in discharge air	<ol style="list-style-type: none"> <li>1. Hot humid weather</li> <li>2. Water accumulated in the tank</li> </ol>	<ol style="list-style-type: none"> <li>1. During hot and humid weather it is normal to accumulate water in the compressor tank. This is normal and requires frequent draining of tank. We recommend use of an automatic drain along with filters and dryers if this is a problem</li> <li>2. Drain tank of water to prevent tank corrosion and air tool wear. It is recommended use of an automatic drain along with filters and dryer to prevent water into exhaust air of the compressor</li> </ol>

Continued on next page

**TROUBLESHOOTING GUIDE FOR UNITS IN SERVICE FOR A PERIOD OF TIME (CONTINUED)**

Symptom	Possible Cause(s)	Corrective Action
Oil in discharge air	<ol style="list-style-type: none"><li>1. Restricted intake filter</li><li>2. Wrong type of oil</li><li>3. Worn rings or scored cylinder</li><li>4. Compressor running hot</li></ol>	<ol style="list-style-type: none"><li>1. The filter should be changed frequently to avoid possible problems and to make the compressor operation efficient. There is a vacuum created in the intake of the compressor, which causes high oil consumption by pulling oil through the rings. There is also a chance of the intake filter media being destroyed, allowing contaminants to enter the intake and cause wear problems</li><li>2. Do not use SAE-30 automotive type oil. Using the wrong oil can cause various problems with the pump and will void the warranty. Only use the oils that the operating manual recommends</li><li>3. Replace rings and/or replace cylinder</li><li>4. Make sure compressor is running the correct rotation. Compressor should be clean and in a well ventilated area. Oil should be changed on regular intervals according to the specifications listed in the manual. Air filter must be changed as it gets dirty</li></ol>



## MAINTENANCE AND INSPECTION INSTRUCTIONS



### **⚠ WARNING**

**Disconnect, tag and lock out power source then release all pressure from the system before attempting to install, service, relocate or perform any maintenance.**

In order to maintain efficient operation of the compressor system, check the air filter and oil level before each use. The ASME safety valve should also be checked daily (see Figure 10). Pull ring on safety valve and allow the ring to snap back to normal position. This valve automatically releases air if the tank pressure exceeds the preset maximum. If air leaks after the ring has been released, or the valve is stuck and cannot be actuated by the ring, the ASME safety valve must be replaced.

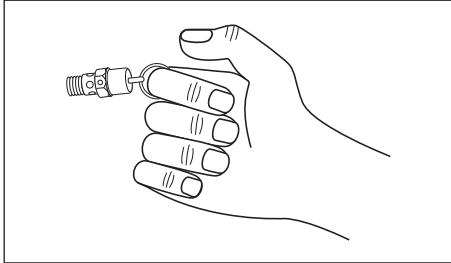

**Figure 10 - ASME Safety Valve**

### **⚠ WARNING**

**Do not tamper with the ASME safety valve.**

### **Tank**



### **⚠ WARNING**

**Never attempt to repair or modify a tank! Welding, drilling or any other modification will weaken the tank resulting in damage from rupture or explosion. Always replace worn, cracked or damaged tanks.**

### **NOTICE**

**Drain liquid from tank daily.**

The tank should be carefully inspected at a minimum of once a year. Look for cracks forming near the welds. If a crack is detected, remove pressure from tank immediately and replace.

### **Compressor Lubrication**

See Installation. Add oil as required. The oil should be changed every three months or after every 500 hours of operation; whichever comes first.

If the compressor is run under humid conditions for short periods of time, the humidity will condense in the crankcase and cause the oil to look creamy. Oil contaminated by condensed water will not provide adequate lubrication and must be changed immediately. Using contaminated oil will damage bearings, pistons, cylinders and rings and is not covered under warranty. To avoid water condensation in the oil, periodically run the compressor with tank pressure near 150 psi for two-stage compressors or 120 psi for single stage compressors by opening the drain cock or an air valve connected to the tank or hose. Run the pump for an hour at a time at least once a week or more often if the condensation reoccurs.

**IMPORTANT:** Change oil after first 50 hours of operation.

### **Air Filter**

Never run the compressor pump without an intake air filter or with a clogged intake air filter. The air filter element should be checked monthly (see Figure 11). Operating compressor with a dirty filter can cause high oil consumption and increase oil contamination in the discharge air. If the air filter is dirty it must be replaced.



**Figure 11 - Air Filter**

## MAINTENANCE AND INSPECTION INSTRUCTIONS (CONTINUED)

### Intercooler



**Intercooler fins are sharp, always wear gloves and use care when you clean or work near the intercooler.**

Weekly, check the intercooler to be sure all fittings are secure and tight. Clean all dirt, dust and other accumulations from the intercooler fins.

### Components

Turn off all power and clean the cylinder head, motor, fan blades, air lines, intercooler and tank on a monthly basis.

### Belts



**Lock out and tag the power then release all pressure from the tank to prevent unexpected movement of the unit.**

Check belt tension every 3 months. Adjust belt tension to allow 3/8 inch to 1/2 inch deflection with normal thumb pressure. Also, align belts using a straight edge against the face of the flywheel and touching the rim on both sides of the face. The belts should be parallel to this straight edge (see Figure 12). Dimension A should be the same as B and C to ensure proper alignment of the belts.

Slots in the bed-plate allow for sliding the motor back and forth to adjust belt tension.

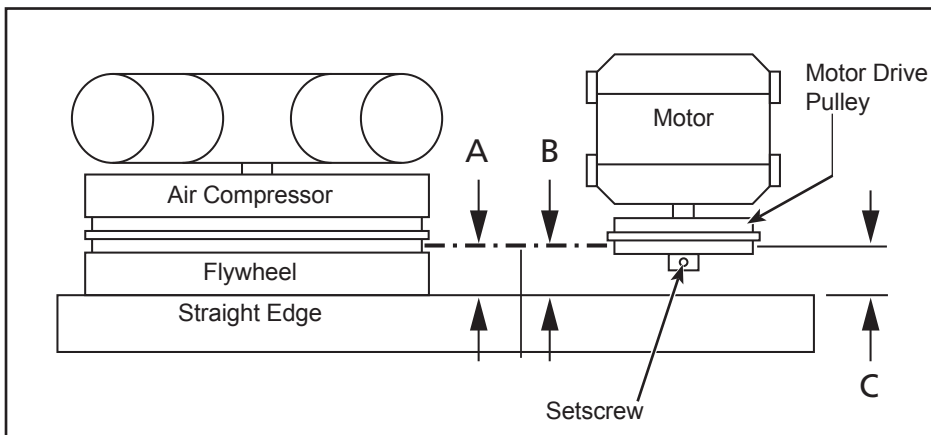
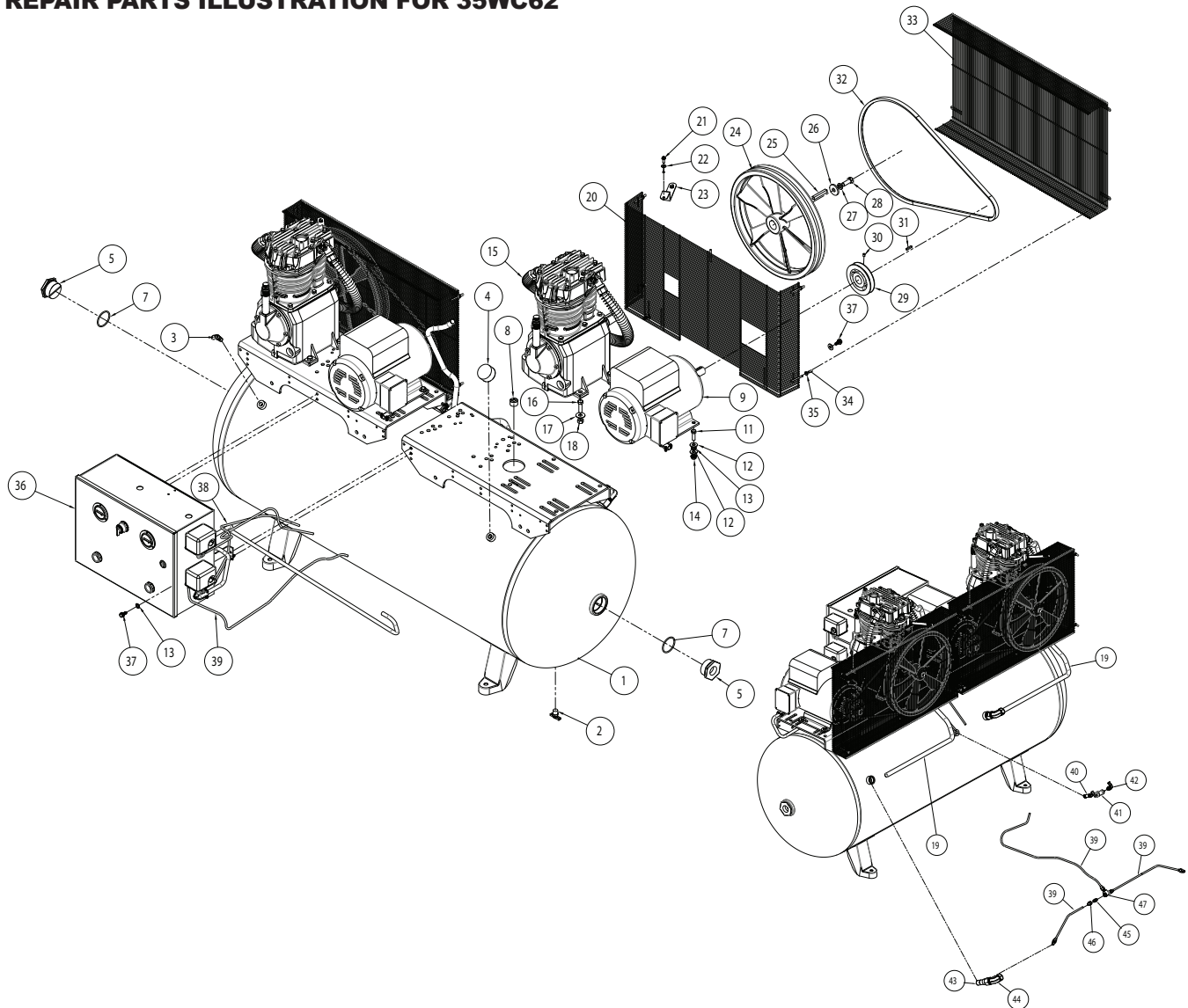

Figure 12 - Top View

### Maintenance Schedule

Operation	Daily	Monthly	3 Months
Check Safety Valve	●		
Drain Tank (see Figure 9)	●		
Check Oil Level	●		
Clean or Change Air Filter		●	
Check Intercooler		●	
Clean Unit Components		●	
Check Belt Tightness			●
Change Oil (see Figure 7)			●

## REPAIR PARTS ILLUSTRATION FOR 35WC62



Ref. No.	Description	Part Number:	Qty.
1	120 GALLON COMPRESSOR	AR235800CG	1
2	DRAIN COCK 3/8	45U948	1
3	SAFETY VALVE 200PSI	33MH70	1
4	300 PSI 1/4" NPT PRESSURE GAUGE	GA031901AV	1
5	2" SOLID PLUG W/O-RING	PG201001AV	1
6	2" X 1" REDUCER W/O-RING	ST070311AV	1
7	O-RING-2.109 ID-0.139 CS	ST049900AV	2
8	PLUG PIPE-SQHD 3/4" NPT	+	1

**For Repair Parts, call 1-800-Grainger**  
**24 hours a day – 365 days a year**

Please provide following information:

- Model number
- Serial number (if any)
- Part description and number as shown in parts list



## REPAIR PARTS LIST FOR 35WC62

Ref. No.	Description	Part Number:	Qty.
9	MOTOR 230V 1 PH	MC025100AV	2
10	WIRE NUT	ST073008AV	6
11	HHCS 3/8-16 1.25 LG-CLEAR ZINC-STEEL-GR2	ST070638AV	8
12	WASHER-3/8-W-ID 0.438 OD 1-CLEAR ZINC	ST070914AV	16
13	EXT TOOTH WASHER	ST072608AV	3
14	3/8"-16 FLANGE NUT	ST033500AV	8
15	TF PUMP ASSEMBLY	5F566	2
16	HHCS 7/16-14 1.5 LG-CLEAR ZINC-STEEL-GR5	†	8
17	WASHER-7/16-W-ID 0.5 OD 1.25-CLEAR ZINC	ST070916AV	8
18	HEX NUT 7/16-14 -ZINC	†	8
19	EXHAUST TUBE PUMP TO TANK	CE100002AP	2
20	BELTGUARD BACK	BG217100AV	2
21	#1/4-20 SELF-TAPPIING HEX SCREW	ST074415AV	3
22	WASHER-1/4-N-ID 0.281 OD 0.625-CLEAR ZINC	ST070910AV	2
23	WIRE BELT GUARD BRACKET	CE001500AV	2
24	16" CAST IRON FLYWHEEL	PU016701AV	2
25	FLYWHEEL KEY	KE001310AV	2
26	WASHER	TX034600AV	2
27	1/2" LOCK WASHER	†	2
28	1/2"-13 X 1 1/4" BOLT	†	2
29	PULLEY 4.6X1.125	--	2
30	SET SCREW	--	2
31	KEY 3/16 X 1	KE000903AV	2
32	BELT	BT008501AV	2
33	SQUARE WIRE BELT GUARD FRONT	BG217000AV	2
34	SAFETY CAP	ST075400AV	8
35	NUT 10-24 HEX FLANGE	ST116201AV	8
36	DELUXE PANEL 7.5HP 1PH DUPLEX	--	1
37	5/16-12 SELF TAPPING HEX SCREW	ST016500AV	8
38	NYLON PRESSURE TUBING	†	2.5 FT
39	TUBE UNLOADER	TF063501AP	2 FT
40	2" X 1/4" NPT PIPE NIPPLE	†	1
41	1/8 NPT TEE	ST049900AV	1
42	1/4" TUBE 1/4" NPT PUSH CONNECT	ST119702AV	2
43	CHECK VALVE	33MH64	2
44	3/4 NPT PIPE ELBOW	ST072231AV	2
45	STRAIGHT FLARE 1/4TX1/8P	†	5
46	FLARE NUT 1/4	†	5
47	SHUTTLE VALVE	†	1
--	NOT AVAILABLE		
†	AVAILABLE AT LOCAL HARDWARE STORE		

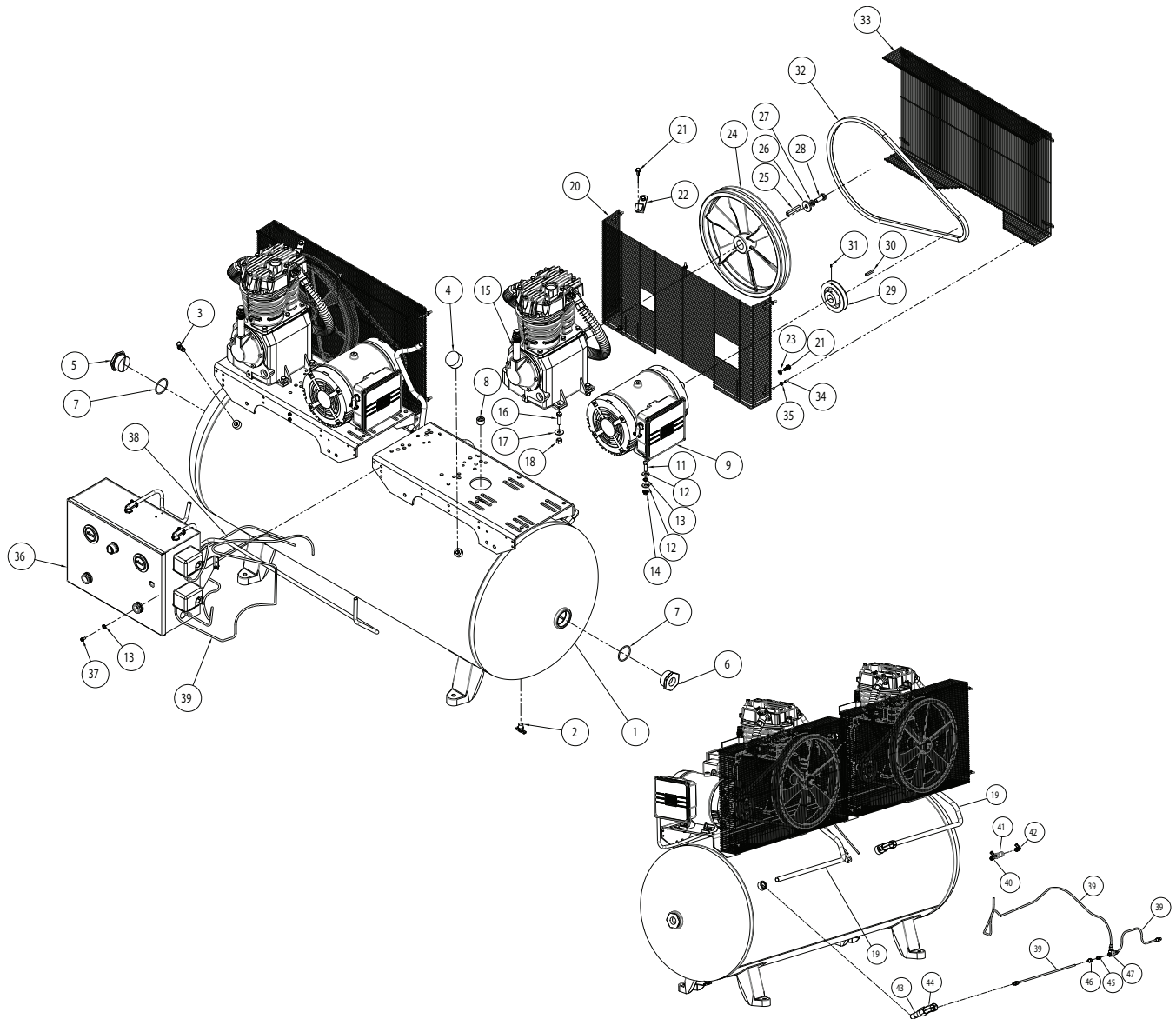
**REPAIR PARTS ILLUSTRATION FOR 35WC63**

Ref. No.	Description	Part Number:	Qty.
1	120 GALLON COMPRESSOR	AR235800CG	1
2	DRAIN COCK 3/8	45U948	1
3	SAFETY VALVE 200PSI	V-209000AV	1
4	300 PSI 1/4" NPT PRESSURE GAUGE	GA031901AV	1
5	2" SOLID PLUG W/O-RING	PG201001AV	1
6	2" X 1" REDUCER W/O-RING	PG201003AV	1
7	O-RING-2.109 ID-0.139 CS	ST070190AV	2
8	PLUG PIPE-SQHD 3/4" NPT	†	1

**For Repair Parts, call 1-800-Grainger**  
**24 hours a day – 365 days a year**

Please provide following information:

- Model number
- Serial number (if any)
- Part description and number as shown in parts list

## REPAIR PARTS LIST FOR 35WC63

Ref. No.	Description	Part Number:	Qty.
9	MOTOR 7.5HP 3PH	MC033600AV	2
10	WIRE NUT	ST073008AV	6
11	HHCS 3/8-16 1.25 LG-CLEAR ZINC-STEEL-GR2	ST070638AV	8
12	WASHER-3/8-W-ID 0.438 OD 1-CLEAR ZINC	ST070914AV	16
13	EXT TOOTH WASHER	ST072608AV	3
14	3/8"-16 FLANGE NUT	ST033500AV	8
15	TF PUMP ASSEMBLY	5F566	2
16	HHCS 7/16-14 1.5 LG-CLEAR ZINC-STEEL-GR5	†	8
17	WASHER-7/16-W-ID 0.5 OD 1.25-CLEAR ZINC	ST070916AV	8
18	HEX NUT 7/16-14 -ZINC	†	8
19	EXHAUST TUBE PUMP TO TANK	CE100002AP	2
20	BELTGUARD BACK	BG217100AV	2
21	5/16-12 SELF TAPPING HEX SCREW	ST016500AV	8
22	WIRE BELT GUARD BRACKET	CE001500AV	2
23	5/16" WASHER	ST011200AV	4
24	16" CAST IRON FLYWHEEL	PU016701AV	2
25	FLYWHEEL KEY	KE001310AV	1
26	WASHER	TX034600AV	1
27	1/2" LOCK WASHER	†	1
28	1/2"-13 X 1 1/4" BOLT	†	1
29	PULLEY 4.6X1.125	PU009750AV	2
30	PULLEY KEY 1/4" X 1.5" LG	--	1
31	SET SCREW	--	2
32	BELT BX-66	BT008501AV	2
33	BELTGUARD FRONT	BG217000AV	2
34	SAFETY CAP	ST075400AV	10
35	NUT 10-24 HEX FLANGE	ST116201AV	10
36	DELUXE PANEL 7.5 HP, 1PH DUPLEX	--	1
37	SCREW SLF TAP 1/4-20X1/2	TF004801AV	4
38	NYLON PRESSURE TUBING	†	2.5 FT
39	UNLOADER TUBE	TF063501AP	2 FT
40	1.5" X 1/4" NPT PIPE NIPPLE	†	1
41	1/8 NPT TEE	ST049900AV	1
42	1/4" TUBE 1/4" NPT PUSH CONNECT	ST119702AV	2
43	CHECK VALVE	33MH64	2
44	3/4 NPT PIPE ELBOW	ST072231AV	2
45	STRAIGHT FLARE 1/4TX1/8P	†	5
46	FLARE NUT 1/4	†	5
47	SHUTTLE VALVE	†	1
--	NOT AVAILABLE		
†	AVAILABLE AT LOCAL HARDWARE STORE		

## REPAIR PARTS ILLUSTRATION FOR 35WC60

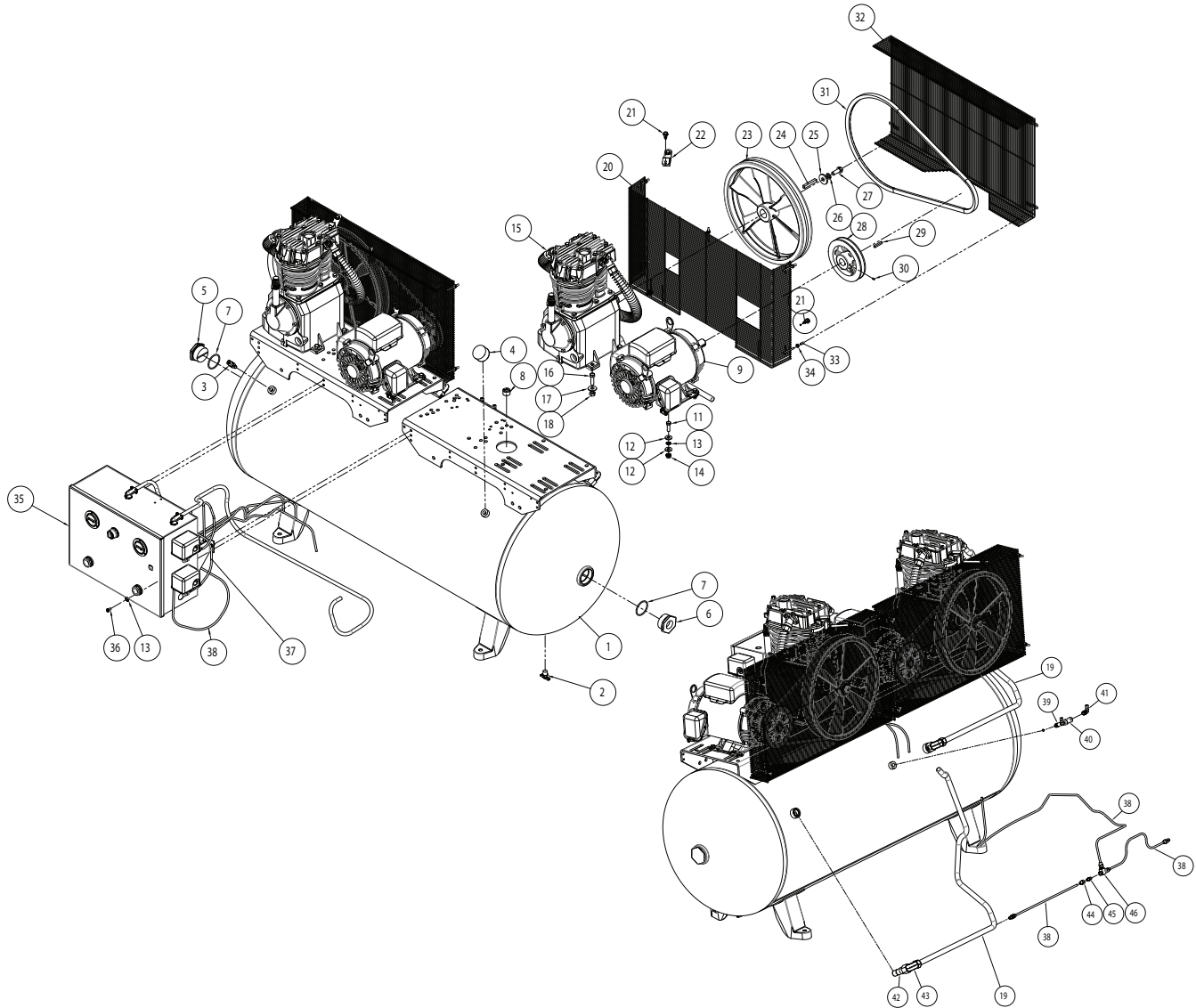

Ref. No.	Description	Part Number:	Qty.
1	120 GALLON COMPRESSOR	AR235800CG	1
2	DRAIN COCK 3/8	45U948	1
3	200PSI SAFETY VALVE	V-209000AV	1
4	300 PSI 1/4" NPT PRESSURE GAUGE	GA031901AV	1
5	2" SOLID PLUG W/O-RING	PG201001AV	1
6	2" X 1" REDUCER W/O-RING	PG201003AV	1
7	O-RING-2.109 ID-0.139 CS	ST070190AV	2
8	PLUG PIPE-SQHD 3/4" NPT	†	1

**For Repair Parts, call 1-800-Grainger**  
**24 hours a day – 365 days a year**

Please provide following information:

- Model number
- Serial number (if any)
- Part description and number as shown in parts list

## REPAIR PARTS LIST FOR 35WC60

Ref. No.	Description	Part Number:	Qty.
9	MOTOR 5HP 1PH	45U933	2
10	WIRE NUT	ST073008AV	2
11	HHCS 3/8-16 1.25 LG-CLEAR ZINC-STEEL-GR2	ST070638AV	8
12	WASHER-3/8-W-ID 0.438 OD 1-CLEAR ZINC	ST070914AV	16
13	EXT TOOTH WASHER	ST072608AV	3
14	3/8"-16 FLANGE NUT	ST033500AV	8
15	TF PUMP ASSEMBLY	5Z404	2
16	HHCS 7/16-14 1.5 LG-CLEAR ZINC-STEEL-GR5	†	8
17	WASHER-7/16-W-ID 0.5 OD 1.25-CLEAR ZINC	ST070916AV	8
18	HEX NUT 7/16-14 -ZINC	†	8
19	EXHAUST TUBE PUMP TO TANK	CE100002AP	2
20	BELTGUARD BACK	BG217100AV	2
21	5/16-12 SELF TAPPING HEX SCREW	ST016500AV	8
22	WIRE BELT GUARD BRACKET	CE001500AV	2
23	16" CAST IRON FLYWHEEL	PU016701AV	2
24	FLYWHEEL KEY	KE001310AV	1
25	WASHER	TX034600AV	1
26	1/2" LOCK WASHER	†	1
27	1/2"-13 X 1 1/4" BOLT	†	1
28	PULLEY 6.7 1-3/8 BORE	PU008003AV	2
29	PULLEY KEY 1/4" X 1.5" LG	--	1
30	SET SCREW	--	2
31	BELT B67	BT022001AV	2
32	BELTGUARD FRONT	BG217000AV	2
33	SAFETY CAP	ST075400AV	10
34	NUT 10-24 HEX FLANGE	ST116201AV	10
35	DELUXE PANEL 7.5 HP, 1PH DUPLEX	--	1
36	SCREW SLF TAP 1/4-20X1/2	TF004801AV	4
37	NYLON PRESSURE TUBING	†	2.5 FT
38	TUBE UNLOADER	TF063501AP	2 FT
39	1.5" X 1/4" NPT PIPE NIPPLE	†	1
40	1/8 NPT TEE	ST049900AV	1
41	1/4" TUBE 1/4" NPT PUSH CONNECT	ST119702AV	2
42	CHECK VALVE	33MH64	2
43	3/4 NPT PIPE ELBOW	ST072231AV	2
44	STRAIGHT FLARE 1/4TX1/8P	†	5
45	FLARE NUT 1/4	†	5
46	SHUTTLE VALVE	†	1
--	NOT AVAILABLE		
†	AVAILABLE AT LOCAL HARDWARE STORE		

## REPAIR PARTS ILLUSTRATION FOR 35WC61

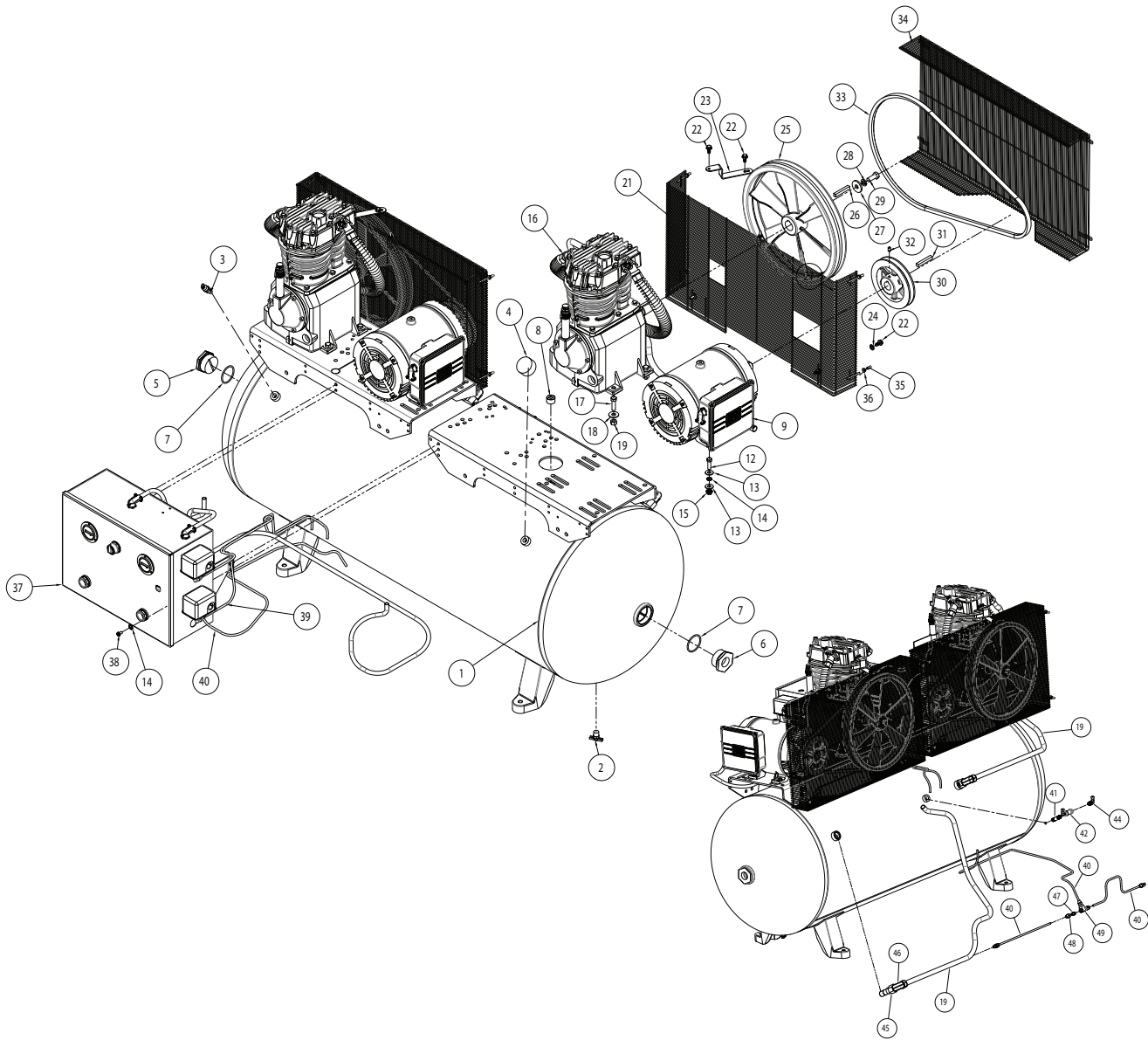

Ref. No.	Description	Part Number:	Qty.
1	SA 120 GALLON COMPRESSOR	AR2335800CG	1
2	DRAIN COCK 3/8	45U948	1
3	200PSI SAFETY VALVE	V-209000AV	1
4	300 PSI 1/4" NPT PRESSURE GAUGE	GA031901AV	1
5	2" SOLID PLUG W/O-RING	PG201001AV	1
6	2" X 1" REDUCER W/O-RING	PG201003AV	1
7	O-RING-2.109 ID-0.139 CS	ST070190AV	2
8	PLUG PIPE-SQHD 3/4" NPT	†	1

**For Repair Parts, call 1-800-Grainger**  
**24 hours a day – 365 days a year**

Please provide following information:

- Model number
- Serial number (if any)
- Part description and number as shown in parts list

## REPAIR PARTS LIST FOR 35WC61

Ref. No.	Description	Part Number:	Qty.
9	MOTOR 5HP	MC033500SJ	2
10	WIRE NUT	ST073008AV	6
11	CONDUIT NUT	ST073504AV	2
12	HHCS 3/8-16 1.25 LG-CLEAR ZINC-STEEL-GR2	ST070638AV	8
13	WASHER-3/8-W-ID 0.438 OD 1-CLEAR ZINC	ST070914AV	16
14	EXT TOOTH WASHER	ST072608AV	3
15	3/8"-16 FLANGE NUT	ST033500AV	8
16	TF PUMP ASSEMBLY	5Z404	2
17	HHCS 7/16-14 1.5 LG-CLEAR ZINC-STEEL-GR5	†	8
18	WASHER-7/16-W-ID 0.5 OD 1.25-CLEAR ZINC	ST070916AV	8
19	HEX NUT 7/16-14 -ZINC	†	8
20	EXHAUST TUBE TANK TO PUMP	CE100002AP	2
21	BELTGUARD BACK	BG217100AV	2
22	5/16-12 SELF TAPPING HEX SCREW	ST016500AV	8
23	WIRE BELT GUARD BRACKET	CE001500AV	2
24	5/16" WASHER	ST011200AV	4
25	16" CAST IRON FLYWHEEL	PU016701AV	2
26	FLYWHEEL KEY	KE001310AV	2
27	WASHER	TX034600AV	2
28	WASHER-1/2-ID 0.509 OD 0.873-MECHANICAL ZINC	†	2
29	HHCS 1/2-13 1.25 LG-CLEAR ZINC-STEEL-GR5	†	2
30	PULLEY 6.7 1-3/8 BORE	PU008003AV	2
31	PULLEY KEY	N/A	2
32	SET SCREW CUP POINT	N/A	2
33	B67 BELT	BT022001AV	2
34	BELTGUARD FRONT	BG217000AV	2
35	SAFETY CAP	ST075400AV	10
36	NUT 10-24 HEX FLANGE	ST116201AV	10
37	DELUXE PANEL 7.5 HP, 1PH DUPLEX	--	1
38	SCREW SLF TAP 1/4-20X1/2	TF004801AV	4
39	NYLON PRESSURE TUBING	†	2.5 FT
40	UNLOADER TUBE	TF063501AP	2.5 FT
41	2" X 1/4" NPT PIPE NIPPLE	ST147100AV	1
42	1/8 NPT TEE	ST049900AV	1
43	1/4" PUSH-CONNECT ELBOW W/ 1/8" NPT	ST081601AV	2
44	1/4" TUBE 1/4" NPT PUSH CONNECT	ST119702AV	2
45	CHECK VALVE	33MH64	2
46	3/4 NPT PIPE ELBOW	ST072231AV	2
47	STRAIGHT FLARE 1/4TX1/8P	†	5
48	FLARE NUT 1/4"	†	5
49	SHUTTLE VALVE	†	1
--	NOT AVAILABLE		
†	AVAILABLE AT LOCAL HARDWARE STORE		



## **SPEEDAIRE THREE-YEAR LIMITED WARRANTY**

**SPEEDAIRE THREE-YEAR LIMITED WARRANTY.** All Speedaire® product models covered in this manual are warranted by W.W. Grainger, Inc. ("Grainger") to the original user against defects in workmanship or materials under normal use for three years after date of purchase. If the Speedaire Product is part of a set, only the portion that is defective is subject to this warranty. Any product or part which is determined to be defective in material or workmanship and returned to an authorized service location, as Grainger or Grainger's designee designates, shipping costs prepaid, will be, as the exclusive remedy, repaired or replaced with a new or reconditioned product or part of equal utility or a full refund given, at Grainger's or Grainger's designee's option, at no charge. For limited warranty claim procedures, see "Warranty Service" below. This warranty is void if there is evidence of misuse, mis-repair, mis-installation, abuse or alteration. This warranty does not cover normal wear and tear of Speedaire Products or portions of them, or products or portions of them which are consumable in normal use. This limited warranty gives purchasers specific legal rights, and you may also have other rights which vary from jurisdiction to jurisdiction.

### **WARRANTY DISCLAIMERS AND LIMITATIONS OF LIABILITY RELATING TO ALL CUSTOMERS FOR ALL PRODUCTS**

**LIMITATION OF LIABILITY.** TO THE EXTENT ALLOWABLE UNDER APPLICABLE LAW, GRAINGER'S LIABILITY FOR CONSEQUENTIAL AND INCIDENTAL DAMAGES IS EXPRESSLY DISCLAIMED. 'S LIABILITY IN ALL EVENTS IS LIMITED TO AND SHALL NOT EXCEED THE PURCHASE PRICE PAID.

**WARRANTY DISCLAIMER.** A DILIGENT EFFORT HAS BEEN MADE TO PROVIDE PRODUCT INFORMATION AND ILLUSTRATE THE SPEEDAIRE PRODUCTS IN THIS LITERATURE ACCURATELY; HOWEVER, SUCH INFORMATION AND ILLUSTRATIONS ARE FOR THE SOLE PURPOSE OF IDENTIFICATION, AND DO NOT EXPRESS OR IMPLY A WARRANTY THAT THE SPEEDAIRE PRODUCTS ARE MERCHANTABILITY, OR FIT FOR A PARTICULAR PURPOSE, OR THAT THE SPEEDAIRE PRODUCTS WILL NECESSARILY CONFORM TO THE ILLUSTRATIONS OR DESCRIPTIONS. EXCEPT AS PROVIDED BELOW, NO WARRANTY OR AFFIRMATION OF FACT, EXPRESSED OR IMPLIED, OTHER THAN AS STATED IN THE "LIMITED WARRANTY" ABOVE IS MADE OR AUTHORIZED BY GRAINGER.

**PRODUCT SUITABILITY.** MANY JURISDICTIONS HAVE CODES AND REGULATIONS GOVERNING SALES, CONSTRUCTION, INSTALLATION, AND/OR USE OF PRODUCTS FOR CERTAIN PURPOSES, WHICH MAY VARY FROM THOSE IN NEIGHBORING AREAS. WHILE ATTEMPTS ARE MADE TO ASSURE THAT SPEEDAIRE PRODUCTS COMPLY WITH SUCH CODES, GRAINGER CANNOT GUARANTEE COMPLIANCE, AND CANNOT BE RESPONSIBLE FOR HOW THE PRODUCT IS INSTALLED OR USED. BEFORE PURCHASE AND USE OF A PRODUCT, REVIEW THE SAFETY/SPECIFICATIONS, AND ALL APPLICABLE NATIONAL AND LOCAL CODES AND REGULATIONS, AND BE SURE THAT THE SPEEDAIRE PRODUCT, INSTALLATION, AND USE WILL COMPLY WITH THEM.

**CONSUMERS ONLY.** CERTAIN ASPECTS OF DISCLAIMERS ARE NOT APPLICABLE TO CONSUMER PRODUCTS SOLD TO CONSUMERS; (A) SOME JURISDICTIONS DO NOT ALLOW THE EXCLUSION OR LIMITATION OF INCIDENTAL OR CONSEQUENTIAL DAMAGES, SO THE ABOVE LIMITATION OR EXCLUSION MAY NOT APPLY TO YOU; (B) ALSO, SOME JURISDICTIONS DO NOT ALLOW A LIMITATION ON HOW LONG AN IMPLIED WARRANTY LASTS, SO THE ABOVE LIMITATION MAY NOT APPLY TO YOU; AND (C) BY LAW, DURING THE PERIOD OF THIS LIMITED WARRANTY, ANY IMPLIED WARRANTIES OF MERCHANTABILITY OR FITNESS FOR A PARTICULAR PURPOSE APPLICABLE TO CONSUMER PRODUCTS PURCHASED BY CONSUMERS, MAY NOT BE EXCLUDED OR OTHERWISE DISCLAIMED.

THIS LIMITED WARRANTY ONLY APPLIES TO SPEEDAIRE PRODUCTS PURCHASED BY UNITED STATES PURCHASERS FOR DELIVERY IN THE UNITED STATES.

### **WARRANTY SERVICE**

To obtain warranty service if you purchased the covered product directly from W.W. Grainger, Inc. ("Grainger"), (i) write or call or visit the local Grainger branch from which the product was purchased or another Grainger branch near you (see [www.grainger.com](http://www.grainger.com) for a listing of Grainger branches); or (ii) contact Grainger by going to [www.grainger.com](http://www.grainger.com) and clicking on the "Contact Us" link at the top of the page, then clicking on the "Email us" link; or (iii) call Customer Care (toll free) at 1-888-361-8649. To obtain warranty service if you purchased the covered product from another distributor or retailer, (i) go to [www.grainger.com](http://www.grainger.com) for Warranty Service; (ii) write or call or visit a Grainger branch near you; or (iii) call Customer Care (toll free) at 1-888-361-8649. In any case, you will need to provide, to the extent available, the purchase date, the original invoice number, the stock number, a description of the defect and anything else specified in this Speedaire Three-Year Limited Warranty. You may be required to send the product in for inspection at your cost. You can follow up on the progress of inspections and corrections in the same ways. Title and risk of loss pass to buyer on delivery to common carrier, so if product was damaged in transit to you, file claim with carrier, not the retailer or Grainger. For warranty information for purchasers and/or delivery outside the United States, please contact:

**W.W. Grainger, Inc.**  
**100 Grainger Parkway, Lake Forest, IL 60045 U.S.A.**  
**or call +1-888-361-8649**