

[E[M]CONOMY]
means:

emco industrial
training

Designed for your profit

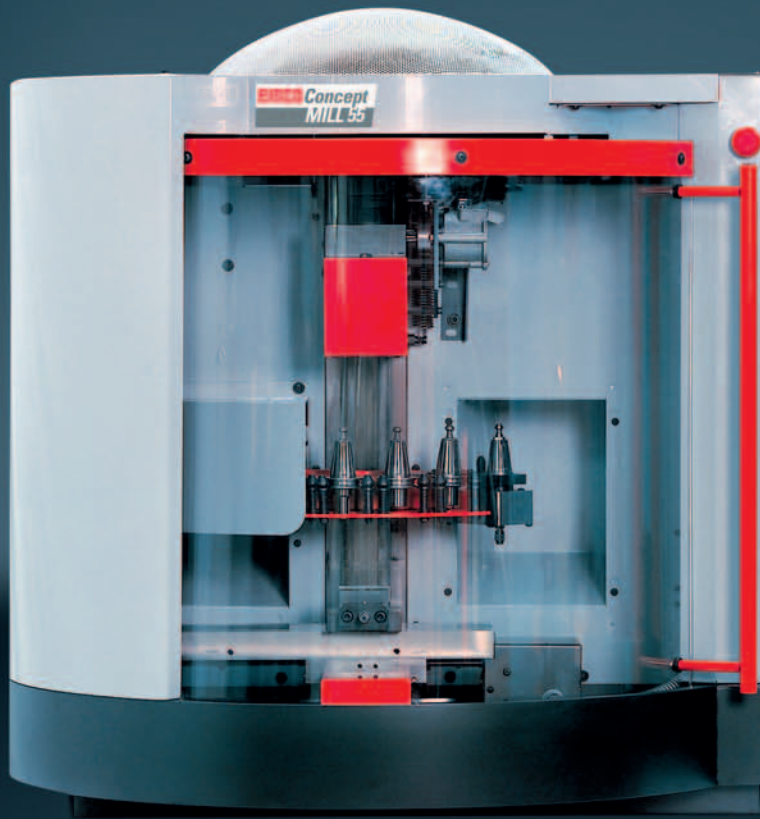

Small Machine. Great Performance. CONCEPT MILL 55

CNC training with industrial performance

Concept MILL 55

This compact milling machine is well suited for CNC training and has almost all the features of an industrial machine: optional with 8-station tool changer with swivel arm and pick-up system, NC indexing device as fourth axis, minimum quantity lubrication and latest state-of-the-art control technology.

[Main drive]

- Infinitely variable main drive
- Three-phase asynchronous motor

[Work area]

- Full cover of work area
- Large safety glass window in door
- All-round protection against chips

[Tool changer]

- 8 stations
- Swivel arm with pick-up system

[Swivel table]

- Extensible drawer for PC keyboard
- Arranged ergonomically

[Machine design]

- Stable, gray cast-iron construction

[Machine base]

- With removable drawer
- Space for PC tower



Attachment

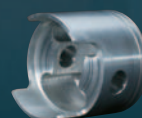

Piston

[Engineering]

Highlights

- Stable, gray cast iron construction
- Clockwise/counterclockwise spindle rotation
- Infinitely variable main drive
- Automatic reference points
- Fully covered work area
- Control EMCO EASY CYCLE integrable
- Made in the Heart of Europe

Options

- 8-station tool changer
- Minimum quantity lubrication
- Electronic handwheel
- Engraving spindle attachment
- NC indexing attachment as optional fourth axis
- DNC robotics interface for integration in FFS or CIM systems
- Machine base with swivel table
- Easy2operate

[The interchangeable control]

The unique concept of the interchangeable control can be fitted to all Concept machines. In doing so, the user is trained on all CNC industry controls that are common on the market.

The result: All CNC technicians can be applied more flexibly. And this is a decisive plus: for qualified employees as well as for the business.



The conversion to another control system is carried out within a minute by calling up the respective software and by simply replacing the controller specific module.

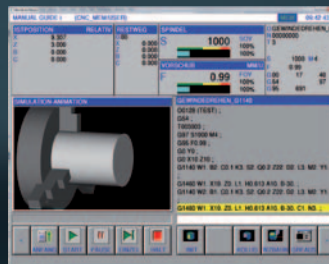

Simple to program using the EMCO WinNC control units

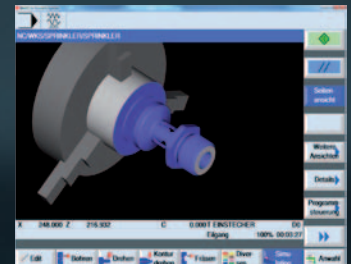

Simulation suitable for training using Win3D-View

[Easy2control: New operating concept]

Optional it is possible to equip the machine with the latest software of the interchangeable control, with which control specific and machine keyboards of the WinNC can be displayed on a 16:9 Full-HD screen – Easy2control. The different panels for machine, control and quick access can be switched via tabs.

The buttons and rotary knobs can either be operated by using the mouse or in case a Full HD touchscreen is used directly on the keys and switches on the monitor.

To operate the software on the Concept machine a license dongle and a small machine control panel - „Easy2operate“ – is required.



Easy2control with Easy2operate

[Technical data]

CONCEPT MILL 55

Work area	
Travel in X longitudinal	190 mm (7.48")
Travel in Y latitudinal	140 mm (5.51")
Travel in Z vertical	260 mm (10.24")
Effective Z-stroke	120 / *190 mm (4.7 / 7.5")
Distance spindle nose - table	77 – 337 mm (3.03 x 13.26")
Table	
Clamping area (L x W)	420 x 125 mm (16.54 x 4.92")
Max. table load	10 kg
2 T-slots DIN 650	11 mm (0.43")
T-slot spacing	90 mm (3.54")
Milling spindle	
Bearing type	roller bearing
Tool change (Option)	
No. of tool stations	8
Max. tool weight	1 kg
Max. tool diameter	40 / *60 mm (1.6 / 2.4")
Motion speed tool swivel arm	10 m/min (0.39 ipm)
Tool clamping	automatic
Milling spindle drive	
Motor power 3 phase asynchronous motor	0.75 kW
Speed range	150 – 3500 rpm
Max. torque	3.7 Nm (2.72 ft/lbs)
Speed with optional engraving spindle	14000 min-1
Feed drive	
3 phase step motor in X / Y / Z axis with resolution	0,5 µm / 0,5 µm / 0,5 µm
Rapid motion speed and feed rate X / Y / Z	0 – 2 m / min (0 – 78.74 ipm)
Average positioning variation in	8 µm / 8 µm / 8 µm

Feed drive	
VDI/DGQ 3441 in X / Y / Z	
Feed power X / Y / Z [N]**	800 / 800 / 1000
Lubrication system	
Guideways	Oil lubrication
Main spindle bearing service life	Grease lubrication
Dimensions	
Dimensions W x D x H	960 x 1000 x 980 mm (37.76 x 39.33 x 38.55")
Total weight	220 kg
Electrical connection	
Voltage supply (adjustable)	1/N/PE [V] 115/230
Admissible voltage fluctuation	+5 / -10 %
Frequency	50/60 Hz
Connection value	0,85 kVA
Maximum pre-fusing of machine	12 A

* without toolchanger

EMCO WinNC control units

Sinumerik Operate 840D sl / 828D	FANUC Series 21
Sinumerik 810D / 840D	FANUC Siereis 0
Sinumerik 810 / 820	Emcotronic TM02
EMCO EASY CYCLE	CAMConcept
FAGOR 8055 MC	Heidenhain TNC 426 / 430
FANUC Series 31i	

User Interface for Easy2control

Sinumerik Operate 840D sl / 828D	FANUC Series 31i
Siemens 810D / 840D	FAGOR 8055 TC
HEIDENHAIN TNC 426 / 430	

Machine layout

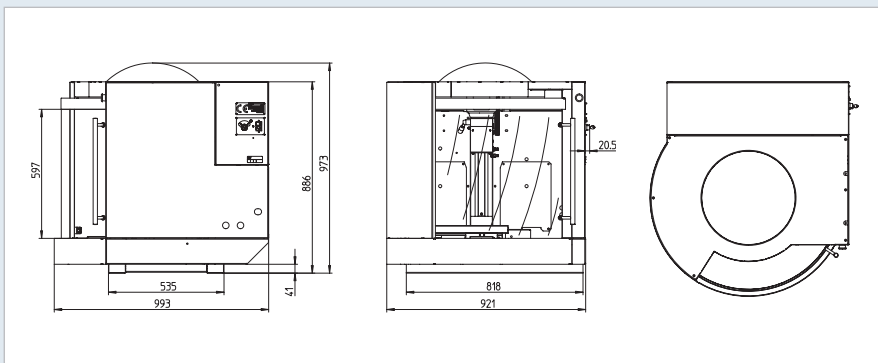

Power

